

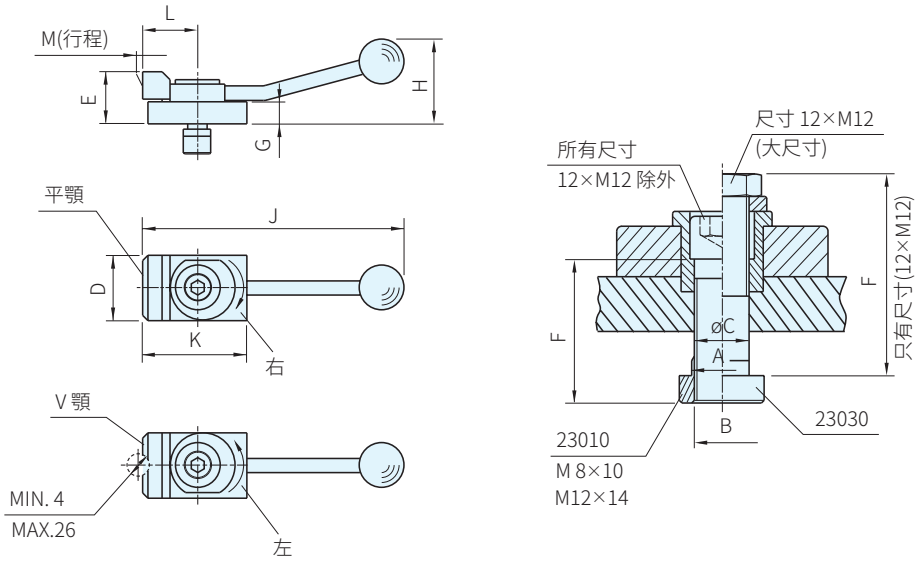

材質	處理
鋼	表面硬化、染黑



品號	特性	A 槽溝尺寸	B	C	D	E	F	G
23210.0101		10	M8	8.4	32	20	30	8
23210.0321	平顎，右旋	12	M12	12.5	48	38	63	16
23210.0341		14					40	
23210.0105	平顎，左旋	10	M8	8.4	32	20	30	8
23210.0325		12	M12	12.5	48	38	63	16
23210.0345		14					40	
23210.0102	V顎，右旋	10	M8	8.4	32	20	30	8
23210.0322		12	M12	12.5	48	38	63	16
23210.0342	14	40						
23210.0106	V顎，左旋	10	M8	8.4	32	20	30	8
23210.0326		12	M12	12.5	48	38	63	16
23210.0346		14					40	

品號	H	J	K	L	M	水平夾緊力 MAX. KN	質量 g	庫存
23210.0101	40	132	50	32	3	3.5	262	△
23210.0321	62	190	72	40	4	7.0	870	△
23210.0341							845	△
23210.0105	40	132	50	32	3	3.5	262	△
23210.0325	62	190	72	40	4	7.0	868	△
23210.0345							847	△
23210.0102	40	132	50	32	3	3.5	263	△
23210.0322	62	190	72	40	4	7.0	893	△
23210.0342							838	△
23210.0106	40	132	50	32	3	3.5	264	△
23210.0326	62	190	72	40	4	7.0	900	△
23210.0346							841	△

**SP. 特長**

- 此夾具鎖緊時，夾持力往前及向下鎖
- 適用於薄工件夾持
- 配合23280使用可任意移動

 訂貨：  交期：  

23210.0101

**WA. 注意**

- 1KN=101.972kgf

**EX. 使用例**